

## PFAS in electrical power transmission & distribution (T&D) equipment

Application of T&D equipment

### Introduction

Transmission and distribution equipment are critical components of the electrical network. From the point of power generation, they transport, convert, and distribute electrical energy across different voltage levels. In addition to energy transfer, network protection is a key function: failures caused by external disturbances or internal faults must be detected, isolated, and controlled to minimize outages and prevent damage. The high energy levels involved demand the strictest safety standards for operator protection, as defined by technical regulations. Given that these assets are designed for lifetimes of 40 years or more, the materials and technical solutions employed must exhibit exceptional durability, low maintenance requirements, and reliable performance across wide temperature ranges. Meeting these stringent demands has historically necessitated the use of materials with specialized properties, which in many cases led to the application of PFAS or PFAS-containing components.

#### Principal overview power-, transmission- and distribution network

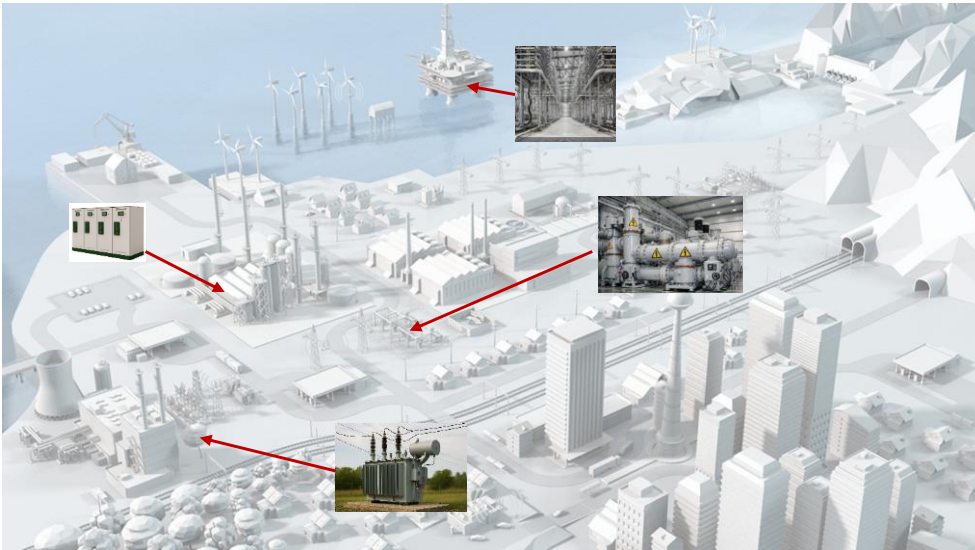

Fig. 1: Products and T&D equipment landscape (AI-generated)

Taking the example of medium- and high-voltage switchgear, it is obvious that, between power generation and consumption, the current passes through 5 to 10 switchgear units. The EU initiative of a full electric society will make the need for reliable products even higher than today.

## Switchgears in the electrical network

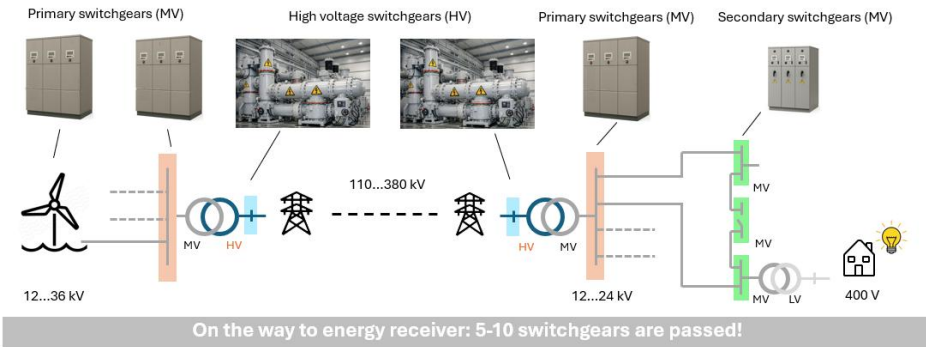

Fig. 2: Products and equipment landscape (AI-generated; MV = Medium Voltage (1 to 52 kV); HV = High Voltage (>52 kV))



## Product(s):

- **High- and Medium-Voltage switchgear and circuit breakers:** electrical energy passes from generation, over distribution to end user multiple high- and medium voltage switchgear with two fundamental functions. The mechanical switching devices connect and disconnect current circuits controlling power loads. In case of failures, circuit breakers or fuses (in medium voltage (MV)) protect power grid systems against the consequences of overcurrent and short circuit.
- **High- and Medium-Voltage Distribution and Power Transformer:** transform the voltage up to high or ultra-high voltage for transmission of electric power over long distances and down to low voltage for supplying consumer's load.
- **High-Voltage Converter:** device for HVDC transmission for energy over long distance power lines to onshore AC electrical power grids. The usage of direct current is reducing the transport losses.

## Users of T&D equipment

- **Transmission System Operators:**  
E.g., in Germany: 50Hertz, Amprion, TenneT, TransnetBW and international: Terna, RTE, REE, National Grid and more.  
In total, 30 in the EU, municipalities, cities or industrial users like large manufacturers with e.g. own power generation.
- **Distribution System Operators** (866 in Germany, about 2600 in the EU)  
for the distribution on medium voltage level in city and rural networks down to the end users on low voltage levels, using several hundred thousand of compact substations.  
(see <https://de.statista.com/themen/2446/stromnetzbetreiber-in-deutschland/#topicOverview>)
- **Renewables**  
The transformation of the energy generation to wind and solar has two significant consequences, resulting in increased volumes in the next decades: the power of each generation unit is much smaller than of a coal or nuclear power plant, e.g. 10 MW each instead of 1500 MW of one nuclear reactor. This increases the need for MV switchgear and HV switchgear (lower voltage level, e.g. 110kV) dramatically. Concentration of generation in the North Sea required long distance transport to the south of Germany with HV lines.

hat formatiert: Englisch (Vereinigtes Königreich),  
Ligaturen: Keine

### Power delivery and charging infrastructure backbones

- Sector coupling through the energy transition
  - scheduled electrification of transportation by a transfer to electrical vehicles (EV) and the transfer to heat pumps replacing fossil heating will create additional demand of electricity.
- AI / Digitalization
  - The fastest growing applications using significant amounts of energy are data centres (actual figure for Germany about 2 GW). Estimates see an impact of AI, which might triple this demand until 2030. (see <https://www.imf.org/en/Blogs/Articles/2025/05/13/ai-needs-more-abundant-power-supplies-to-keep-driving-economic-growth>)



### Market Information:

- In the EU - and especially in Germany - there are many distribution system operators (DSOs), transmission system operators (TSOs), and producers of medium- and high-voltage equipment. The major German TSOs each manage multi-billion-euro investment volumes and employ several thousand people, while the largest DSO has a workforce in the tens of thousands. Beyond public network operators, a substantial share of medium- and high-voltage equipment is used directly in industrial and commercial environments. Limited availability or restricted access to such equipment can strongly affect industrial operations and, as a result, has broader implications for Germany's economic performance.
- There is currently no T&D equipment (e.g. transformer, switchgear, converter) free of PFAS on the market. A ban without derogations will have consequences for all manufacturers and operators of such equipment, as well as for the supply chain. Time is needed for replacements. Linked with T&D equipment are the businesses of construction of buildings and transmission lines, as well as personnel at TSOs and DSOs.
- There are no alternatives to T&D equipment, as it is essential for the transmission and distribution of electrical energy. Enabling transmission and distribution without PFAS-containing components may require extensive redesign efforts and the phase-out of established PFAS-based solutions. If these adaptations aren't technically possible, it would greatly impact both industry and society. In addition, potential impacts on grid stability and overall system availability cannot be ruled out, which could also affect the resilience of the energy infrastructure.
- For some applications with intentionally used/added PFAS, research is ongoing to identify alternatives with at least similar performance required for the functioning of the T&D equipment. For example, epoxy resin, lubricants and PTFE applications. Research conducted to date has, in some cases, concluded that no drop-in substitutes are available. Manufacturers are taking steps to replace PFAS materials; time is needed to find alternatives that meet all technical requirements in the different application areas.
  - **Clean Industrial Deal** (*expansion of renewable energy generation and better power grids*) ([LINK](#))
  - EU Energy Roadmap 2050 ([European Parliament resolution of 14 March 2013 on the Energy roadmap 2050, a future with energy \(2012/2103 \(INI\)\)](#), (2016/C 036/11))
  - Transfer from fuel-based cars to EV until 2035. This requires a network of charging stations requiring MV switchgear in distribution. ([LINK](#))
  - Enhancing the production and use of AI within the EU „AI Continent Action Plan “ ([LINK](#)) require massive data centre in need of electricity
  - Transfer to heat pumps for heating will require additional electrical energy and therefore an upgrade or at least a modernisation of the distribution network ([LINK](#))





## Requirements Profile

- HV switchgear, transformers and converters are designed for a lifetime of 30 to 40 years, supported by specific maintenance cycles using spare parts – 'repair as produced'. Experience on the installed base has shown that these times are often extended up to 50 years or even more, depending very much on the application. Current designs of MV gas insulated switchgear (GIS) are maintenance free for the hermetically sealed high voltage part over lifetime, based on the use of high-quality materials, such as for example PFAS containing lubricants.
- For high-voltage products, **if (alternative) materials are available**, a typical development cycle includes a feasibility study (about 1 year), design (about 1 year), type testing (approximately 3 to 4 years), and certification, resulting in a total duration of about 7 to 10 years, depending on the level of innovation and any cycle repetitions caused by material-related test failures. The overall time frame for MV switchgear is similar, depending on the differences between old and new generation. Due to the huge variance, the design phase is longer (up to 5 years), but the type tests are faster (about 1 year). A complete portfolio renewal will take longer time for type testing.
- Spare parts should be available until end of lifetime, which is a precondition for the designed functioning and a contractual requirement from the customer. Any change in spare part material type for a product in operation will entail invalid certificates and repeat type tests (which is a challenge for already out-phased T&D products, as no test objects can be manufactured), leading to safety risks when these tests are not done. The unavailability of a spare or wear part costing only a few Euros can result in the replacement of T&D equipment in a substation - worth hundreds of thousands of Euros - and lead to the substation being out of service for months or even years. A shutdown of more than one substation in a region might endanger the supply of electricity, based on the n-1 principle. (The "n-1 principle" refers to a rule in power grid planning that ensures the grid can withstand the failure of a single component (like a line or transformer) without causing a power outage).
- **Temperature resistance**
  - As several applications of HV equipment have to withstand outside temperatures in the range -50°C up to 80°C, depending on the operating location worldwide, temperature resistance is considered essential. In specific cases product interior temperatures, e.g. inside an interrupter unit in switchgear or circuit breakers may exceed temperatures far above 1,000°C. The flexibility of sealing rings and the sealing function of greases is required in a wide temperature range (-50°C to 80°C). Greases need to function in an even wider range (-50°C to 120°C) and must be flexible in this temperature range not to block mechanisms. This is a quite challenging requirement! In addition, they need to be resistant to air and humidity.
  - Fluorinated polymer insulated cables and wires are used when high temperatures and long lifetime are required.
- **Dielectric strength**  
In some applications high dielectric strength is required
- **Flame retardancy**  
High flame retardancy, especially in case of failures (e.g. short circuit), is very essential due to electrical currents leading to an increase in temperature of the equipment and sensitive components where fire can start very easily.
- **Friction behaviour**  
As for metals, friction behaviour of plastic parts in mechanical mechanisms is critical for people and equipment's safety
- **Tightness applications**  
where high thermal and oxidative resistance is required.
- **Standards, certification/approvals, market/customer requirements**  
The IEC 62271-x, the main international standard series, serves as the foundation for global acceptance and compliance. Additionally, some customers require local certification.

 **Identified PFAS Uses**  
In the final product

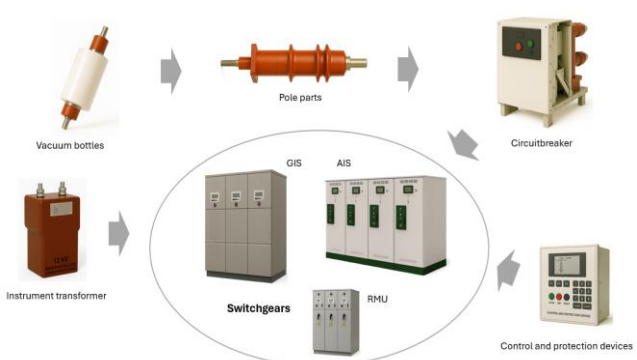
<p>1. <b>HV switchgear and circuit breakers</b></p>	 <p><i>Fig. 3, Image of a high voltage switchgear/circuit breaker (Gas insulated, Air insulated), AI generated</i></p>
<p><b>PFAS substance/substance group:</b></p> <ul style="list-style-type: none"> <li>• Fluoropolymer: PTFE</li> <li>• Fluoroelastomer: FKM</li> </ul>	<p><b>PFAS-containing materials / components:</b></p> <ul style="list-style-type: none"> <li>• PTFE nozzle in arc chamber of gas switches</li> <li>• Gliding rings</li> <li>• Sealing rings</li> <li>• Hot gas distracting and covering parts</li> <li>• Lubricants</li> <li>• Cables and connectors</li> <li>• Electronics, displays and batteries (in control and protection equipment)</li> <li>• Alternative gases</li> </ul> <p>Furthermore, there are numerous applications where PFAS is not explicitly specified but is utilized by suppliers as an additive in a polymer with a non-PFAS base, as a release agent in molding processes, or as a minor component within an assembly. Examples include wire insulation, paint, plugs, valves, and more</p>
<p><b>Reason for PFAS Use/ Requirements Profile:</b></p> <ul style="list-style-type: none"> <li>• Switching arc extinguishing abilities due to PTFE ablation – major functioning (~10,000°C)</li> <li>• High temperature resistance in high-temperature stressed areas (&lt;1,000°C)</li> <li>• Gliding and sealing abilities for moving parts and components for gas or liquid leakage prevention</li> <li>• Protection of sensitive core parts against high temperature impact</li> <li>• Lubrication for moving parts during switching</li> <li>• Dielectric strength</li> </ul> <ul style="list-style-type: none"> <li>• Switching arc extinguishing abilities due to PTFE ablation – major functioning (~10,000°C)</li> <li>• High temperature resistance in high-temperature stressed areas (&lt;1,000°C)</li> <li>• Gliding and sealing abilities for moving parts and components for gas or liquid leakage prevention</li> <li>• Protection of sensitive core parts against high temperature impact</li> <li>• Lubrication for moving parts during switching</li> <li>• Dielectric strength</li> </ul>	

<p>2. MV gas insulated switchgear (GIS), air insulated switchgear (AIS), circuit breaker and load break switches.</p>	 <p>Fig. 4, examples for Medium Voltage Equipment (product pictures AI generated)</p>
<p><b>PFAS substance/substance group:</b></p> <ul style="list-style-type: none"> <li>• Fluoropolymers</li> <li>• Perfluoropolyether oils</li> </ul>	<p><b>PFAS - containing materials / components:</b></p> <ul style="list-style-type: none"> <li>• PTFE nozzle in load break switches</li> <li>• Gliding rings</li> <li>• Sealing rings</li> <li>• Lubricants</li> <li>• Epoxy resin</li> <li>• Electronics, displays and batteries (in control and protection equipment)</li> </ul> <p>Furthermore, there are numerous applications where PFAS is not explicitly specified but is utilized by suppliers as an additive in a polymer with a non-PFAS base e.g. as flame retardant, as a release agent in molding processes, or as a minor component within an assembly. Examples include wire insulation, paint, plugs, valves, and more</p>
<p><b>Reason for PFAS Use/ Requirements Profile:</b></p>	<ul style="list-style-type: none"> <li>• Load break switches arc extinguishing abilities due to PTFE ablation – major functioning (~10,000°C)</li> <li>• Wide temperature range for seals (-35°C to 80°C)</li> <li>• Wide temperature range for grease (-35°C to 120°C) and resistance against air and humidity</li> <li>• Lubrication for moving parts during switching and protection of surfaces in drive mechanisms against corrosion (preventing stuck drive when operating first time after 10 years)</li> <li>• Epoxy resin: homogenous curing without creation of voids for dielectric performance combined with mechanical robustness</li> </ul>

<p>3. <b>Power and Distribution Transformer</b></p>	 <p style="text-align: center;"><i>Fig. 5, image of Power Transformer, AI generated.</i></p>
<p><b>PFAS substance/substance group:</b></p> <ul style="list-style-type: none"> <li>• Fluoropolymer: PTFE</li> <li>• Fluorelastomer: FKM, MFQ</li> </ul>	<p><b>PFAS - containing materials/ components:</b></p> <ul style="list-style-type: none"> <li>• noise damping blocks: FKM, MFQ</li> <li>• seals and gaskets: PTFE</li> <li>• POF- and HCS fiber optical cable with PTFE cladding and buffer</li> <li>• Tap-changer: PTFE in various parts</li> <li>• Bushings: PTFE tape for winding tubes, PTFE insulated cables, spacers</li> <li>• Instrument transformer/ CT (current transducer): PTFE coating</li> </ul>
<p><b>Reason for PFAS Use/ Requirements Profile:</b></p> <ul style="list-style-type: none"> <li>• Sealing abilities</li> <li>• High temperature resistance in high-temperature stressed areas</li> <li>• Chemical resistance against aggressive media (oil)</li> <li>• Mechanical stability</li> <li>• Aging resistance</li> </ul>	

<p>4. <b>HVDC Converter for on- and offshore</b></p>	 <p style="text-align: center;"><i>Fig. 6, image of HVDC Converter station (offshore application), AI generated</i></p>
<p><b>PFAS substance/substance group:</b></p> <ul style="list-style-type: none"> <li>• Fluoropolymer: PVDF, PTFE</li> <li>•</li> </ul>	<p><b>PFAS - containing materials/ components:</b></p> <ul style="list-style-type: none"> <li>• PVDF cooling tubes</li> <li>• PTFE sealing rings POF- and HCS fiber optical cable with PTFE cladding and buffer</li> </ul>
<p><b>Reason for PFAS Use/ Requirements Profile:</b></p> <ul style="list-style-type: none"> <li>• High temperature resistance</li> <li>• High pressure resistance</li> <li>• Chemical resistance against aggressive media (gas, oil)</li> <li>• Dielectric strength</li> </ul>	

## In the production process

In machines and equipment for production

<ul style="list-style-type: none"> <li>Seals in casting molds (epoxy resin or thermoplastic parts)</li> </ul>	
<b>PFAS substance/substance group:</b> <ul style="list-style-type: none"> <li>FKM</li> <li>PTFE</li> </ul>	<b>PFAS- containing materials/ components:</b> <ul style="list-style-type: none"> <li>FKM seals</li> <li>PTFE tubes</li> </ul>
<b>Reason for PFAS Use/ Requirements Profile:</b> <ul style="list-style-type: none"> <li>During the casting process high temperatures of about 160°C are used during filling and curing of the molds for the production of components for switchgear made of epoxy resin or thermoplastic material. The hot material is liquid and under high pressure. The seal has to withstand this. In addition the molds are used frequently and the wear has to be small. Only FKM seals can offer this performance.</li> <li>PTFE tubes used for hot liquids in the production process .</li> </ul>	

## ↔ Substitution

- Currently a small number of PFAS alternatives are known, which might fulfil the required functionality and safety – and under investigation. The overall conclusion, as of today, is that there are no drop-in substitutes available, as requirements can only partly be fulfilled. The performance of the affected components is not identical to the PFAS containing materials used today. The appropriate substitute, if any, must be decided for each application. For example, the replacement of PTFE-nozzles used in gas insulated circuit breakers, switchgears and load break switches do require basic research which has already been started but w/o promising results yet. As the nozzle is essential to successfully interrupt the current, PTFE must be used as long as if there is no adequate drop in solution available. A ban would immediately jeopardize availability of switchgear on the market and consequently impacts the network stability reliability. Currently, R&D resources in, e.g., medium and high voltage switchgear design are engaged in the design changes caused by the replacement of SF6 as insulation gas because of the EU F-gases regulation.

The substitution process begins with substance identification and verification of specific property fulfilment. The substitution time, depending on the product type, includes the product R&D and integration into the designated product range. This is followed by performance and durability testing, along with repeated type tests for all representative models. Finally, the process will move to industrialization, pilot installations, and customer homologation leading to market acceptance. The substitution time itself can take 7 – 10 years taking the conflict with the resource requirements e.g. in R&D efforts into account.

## Safe Use - Prevention and Reduction of Emissions and Exposure

- Emissions in the T&D equipment use phase can be neglected for most applications. For this, the emissions can only occur during manufacturing (mainly of the raw PFAS material), or waste phase. Emission data related to the manufacturing of purchased materials are currently unavailable, as no regulatory reporting requirements exist. Data collection efforts are ongoing; however, responses from supply chain stakeholders remain infrequent and, in some cases, lack sufficient reliability.
- All customers are made aware of following the local legal requirements for waste management when handling materials used in T&D products. Currently there is no specific information regarding PFAS on hand.
- T&D equipment contains a high number of materials such as steel, aluminium and copper, which makes the products very attractive for recycling. It is state-of-the-art that after end-of-life products are handed over to recycling companies, which have sufficient knowledge for best practice on recycling and waste treatment. Residual non-metal content is typically collected and incinerated (thermal recycling).

## (( (O )) Socio-economic Impact Consequences of the Proposed Restriction

- **On product quality and performance**

In some cases, PFAS substitutes are not yet at a stage where they can be used in T&D applications in which PFAS have been intentionally added. In cases where PFAS have not been specifically required, substitutions may be easier to achieve (e.g., additives in paint), although testing is still necessary to verify suitability. A transition to products of lower quality and/or performance is no option in the energy distribution segment. Replacement of T&D equipment is quite complex, time-consuming and expensive and requires partly outages in electrical networks. This needs detailed and complex planning to avoid severe outages in case of failures in the network at the time of replacement. For new alternative materials, the long-term behaviour could increase the risk of hidden series failures which might have a significant impact on reliability of the electrical equipment and by this with the electrical network.
- **On availability of materials**

If a PFAS-free alternative is identified, the availability of possible PFAS-free material might be an issue on the supplier's side, as an increased higher demand for alternatives requires an upscale of their manufacturing lines and quality must be maintained, which takes time. If PFAS substitutes are unavailable within the EU, sourcing externally may increase dependency on non-EU suppliers and risk shortages during geopolitical conflicts.
- **On the sector / industry**

There is a risk that ongoing European power grid projects will be decelerated and won't be finished in time leading to contractual conflicts but more severe shortages of energy. Step out on nuclear energy is done and exit from coal energy is decided, so the transfer to alternative generation needs new equipment to connect those assets into the grid. Without this, the distribution of this energy is not possible, and it is missing. On the other hand, the demand will grow (EV, heat pumps, data centres), so this will create a gap between available and required energy. Extra invest and workforce is required to handle the phase-out properly and in time, leading to a deceleration of innovations. Adding resources in research and development is not only a question of money. Due to the serious shortage of workers in electrical and mechanical engineering and the electrical industry, it is not possible to build-up resources for development.
- **Conflicts with political goals and strategies**

**Clean Industrial Deal:**

  - **CO<sub>2</sub> neutral concept:** efforts in PFAS phase out may decelerate activities, e.g. become CO<sub>2</sub> neutral.
  - **Circular Economy:** Recycling does not seem possible with complete PFAS phase out, as it will become waste at the end of lifetime and result in earlier replacement of functioning equipment due to missing spare parts.

**EU Energy Roadmap**

  - Increase of EU power grid and connections for renewable energy distribution dependent on PFAS free T&D products not available yet to enable grid enhancement.

**Strategic autonomy of Europe**

  - Enhancing competitiveness in critical raw materials, advanced technology, and energy.
  - Identifying and mitigating vulnerabilities in supply chains.
- **Global Competitiveness**

Some non-EU markets have implemented or are considering restrictions on PFAS (per- and polyfluoroalkyl substances) like the US or Canada. Nevertheless, there is a risk that the EU T&D equipment industry will face a huge competitive disadvantage due to cost increases on products without PFAS components and materials due to additional sourcing and R&D efforts in the world markets. Innovations in terms of materials based on PFAS (e.g. for flame retardancy) will be denied to the EU industry, which may endanger global leadership. There is also a risk of dependency on semiconductors not containing PFAS but using PFAS during manufacturing process and being produced outside the EU, allows e.g. Asia to dictate prices without competition, and create further dependency on non-EU manufacturers.

## Burden of Proof and Analytical Aspects

Analytical / instrumental and preparatory requirements / methods to demonstrate compliance are currently not reliable enough for the required PFAS detection within the given threshold (Limit: 25 ppb). Controlling the PFAS content in complex products of mainly solid materials is rather challenging which may not lead to the projected result of the regulation authorities. This needs to be based on the "intentionally added" principle, which can be controlled by bill of material or material recipes. Precondition is here time and resources (equipment, personnel, external laboratories) availability.



### Required Transition Period and/or Derogations

In case no general derogation for the use of fluoropolymers – as requested by ZVEI – will be granted, T&D sector should be given a sufficient derogation time for PFAS fluoropolymer application.

Proposed derogation times for transforming the T&D equipment to cover the typical development cycle:

- a) PFAS alternatives are existent and known
    - **~12 years derogation**  
resulting in: TT +12 years DT = **13,5 years**
  - b) PFAS alternatives are existent but not yet ready for industry
    - **~12 years** derogation (see point a), only if proven PFAS alternatives are commercially available  
resulting in: TT +12 years DT = **13,5 years**
  - c) Drop-in PFAS alternatives with market maturity
    - Currently in some cases no drop-in substitutes are known.
  - d) Availability and usage of spare parts
    - The derogation period for spare parts of 20 years as currently proposed is not sufficient for products with lifetimes of 40 to 50 years. Derogation of 50 years or better until end of equipment lifetime is needed.
- A clearly defined procedure for the reapplication, review and extension of derogations, in case no PFAS-free alternatives are available, should be considered.

DT: Derogation time as of 5 or 12 years, according to Background Document of dossier submitters  
TT: Transition Time of 18 months (according to EU REACH process)



### T&D equipment sector proposal:

It is important that R&D activities are started and funded to ease the industry's transition. Instead of a threshold level of 25 ppb, the restriction should be changed to cover 'intentionally added' PFAS in materials and products.

Rather than taking a universal restriction approach, as set out by the five EU PFAS dossier submitters, a differentiated approach should be taken to replacing PFAS where substitutes are available, while keeping the performance of the products in focus. Additionally, products containing PFAS and with a non-controlled waste stream, high use-phase emissions and/or high total volume should be targeted first. Products and applications should be risk-assessed, taking into account cases where PFAS substitutes are difficult to implement or where loss of performance would be unacceptable. An uncontrolled release into the environment during the use phase from products in the T&D sector is highly unlikely.

### Contact

Arvid Gillert • Senior Manager Energy Technology • Energy Division •  
Phone: +4930 306960 22 • Mobil: +49174 9414 161 • E-Mail: [Arvid.Gillert@zvei.org](mailto:Arvid.Gillert@zvei.org)

Kirsten Metz • Senior Manager Environmental and Chemicals Policy • Sustainability & Environment Division •  
Phone: +4969 6302 212 • Mobil: +49162 2664 952 • E-Mail: [Kirsten.Metz@zvei.org](mailto:Kirsten.Metz@zvei.org)

ZVEI e. V. • Electro and Digital Industry Association • Amelia-Mary-Earhart-Str. 12 • 60549 Frankfurt a.M.  
Germany • Lobby register no.: R002101 • EU Transparency Register ID: 94770746469-09 • [www.zvei.org](http://www.zvei.org)

Date: April 30, 2026